

# INTEC 40KS

## Spring closing unit for hand operated valves (Dead-man`s switching)

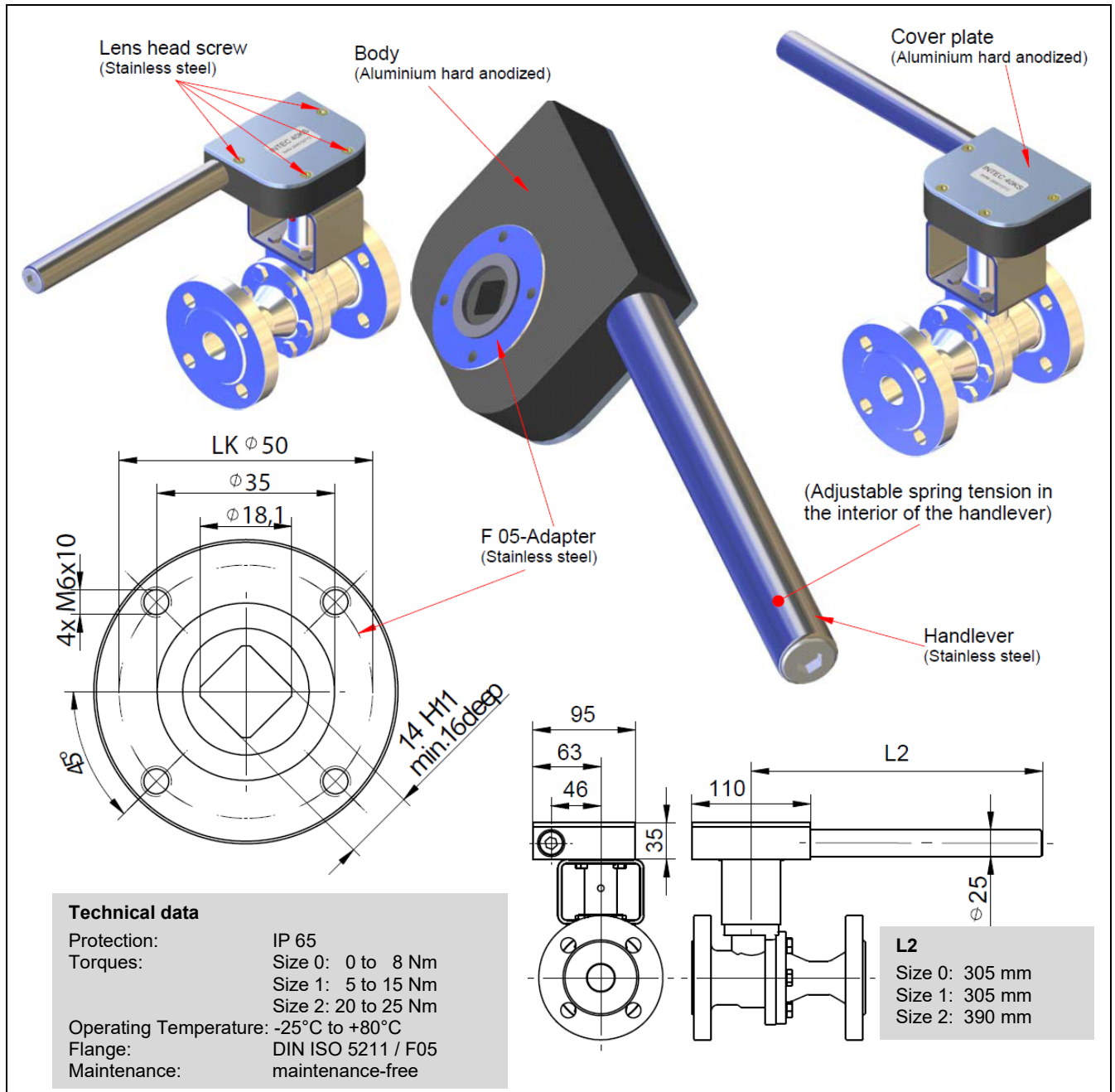

The spring closing unit INTEC 40KS is a user friendly, robust and easy to mounted safety device for all quarter turn valves.

The valve is actuated by the hand-lever. Upon release of the hand-lever the valve will be moved, by the spring force, back to the default safe position (as pre-set).

One of the characteristics of the spring closing unit INTEC 40KS is the possibility of continuous adjustment of the spring-force. This allows for the user, at any time incl. during operation, to make adjustment within a few simple steps to required torque setting.

Adaptions for limit-switches are available on request.